



SVA-C circular VAV dampers

Circular air flow damper for Variable Air Volume (VAV) installations. The **SVA-C** dampers are used to adjust the air flow to a bypass or a room based on a 0-10 V signal provided by a controller of temperature. The command signal sent by the controller of the room, position the actuator to control the flow of the need the enclosure.

A foam seal inside the perimeter of the damper seals the air in case of total closure order.

You can change a posteriori the flow V_{min} and V_{max} using a remote control.

SVA-C

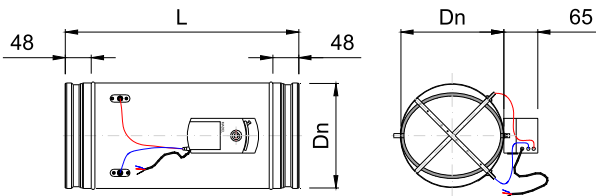

SVA-C/AIS/

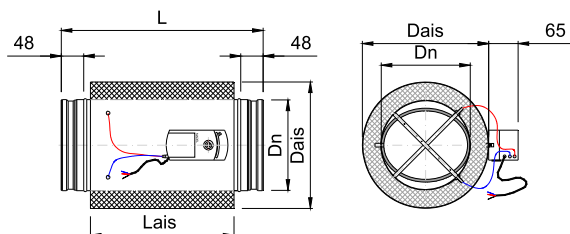

D	Dn	Dais	L	L ais
100	98	178	350	235
125	123	203	350	235
160	158	238	400	286
200	198	278	400	286
250	248	328	450	335
315	313	393	500	385
355	353	433	550	435
400	398	478	600	485

CLASSIFICATION

SVA-C Volume air variable circular damper. Maximum air flow (V_{max}) and minimum (V_{min}) setting calibrated at the factory according to customer specifications. Connection to the duct according to EN-1506 standard. Airtight casing, with rubber seal on the blade, according to EN-1751 standard.

100 < $D(\ddot{R})$ < 125 EN-1751 Caising Class C, Blade 3.
150 < $D(\ddot{R})$ < 400 EN-1751 Caising Class C, Blade 4.

... / **M** / Mode of operation of the damper type Master.

... / **S** / Mode of operation of the damper type Slave.

.../ **CON 0-10**/ 0-10 V proportional control.

.../ **CON 3P**/ 3 points control.

.../ **AIS**/ Thermo-acoustical insulation.

MATERIAL

Galvanized steel housing, cross differential pressure measurement aluminum, connect in ABS and measuring tubes the actuator in red / blue silicone. Damper foam seal from EPDM.

ACCESSORIES

RDG 400 (SIEMENS)

Proportional temperature controller
Ambiance 0...10 Vcc power supply 24vac with backlit digital display, selector comfort / eco / off proportional damper actuators and controllers of compact VAV boxes.

CR24-A1 (BELIMO)

Proportional temperature controller
Ambiance 0...10 Vcc power supply 24vac

RDG 400KN (SIEMENS)

CR24-B1 (BELIMO)

With KNX Communication standard to integrate into BMS

FIXING SYSTEMS

1) Connection into a circular metallic duct.

RDG



CR24



SPECIFICATION TEXT

Supply and mounting of circular VAV damper with cross differential pressure measurement for adjusting the air flow, series **SVA-C/M/CON 0-10/ diam (mm) V_{min} V_{max}** , mode of operation of the damper type Master /**M**/ and 0-10 V proportional control /**CON 0-10**/. Galvanized steel housing, cross differential pressure measurement aluminum, connect in ABS and measuring tubes the actuator in red / blue silicone. Damper foam seal from EPDM. Manufacturer **MADEL**.

SVA-C SERIES

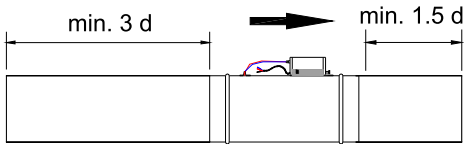

RECOMMENDED AIRFLOW

Ř	Q (m ³ /h)	Dpt (Pa)
100	Qmin 71	20-1000
	Qmax 198	40-1000
125	Qmin 110	20-1000
	Qmax 309	35-1000
160	Qmin 181	20-1000
	Qmax 507	35-1000
200	Qmin 283	18-1000
	Qmax 792	32-1000
250	Qmin 442	17-1000
	Qmax 1237	25-1000
315	Qmin 701	15-1000
	Qmax 1964	22-1000
355	Qmin 891	15-1000
	Qmax 2494	22-1000
400	Qmin 1131	15-1000
	Qmax 3167	22-1000

SOUND POWER LEVEL

Ř	Q	L wa1		
		100 Pa	250 Pa	500 Pa
100	71	38	46	54
	120	46	53	59
	198	50	57	62
125	110	40	54	59
	170	46	56	61
	309	51	58	63
160	181	41	52	57
	300	47	55	62
	507	50	58	63
200	283	41	53	59
	450	46	57	62
	792	49	59	64
250	442	41	54	57
	700	47	58	63
	1237	51	60	65
315	701	42	55	60
	1150	47	58	62
	1964	50	59	63
355	891	43	54	60
	1400	48	58	63
	2494	52	59	64
400	1131	45	54	59
	1750	50	58	63
	3167	53	60	65

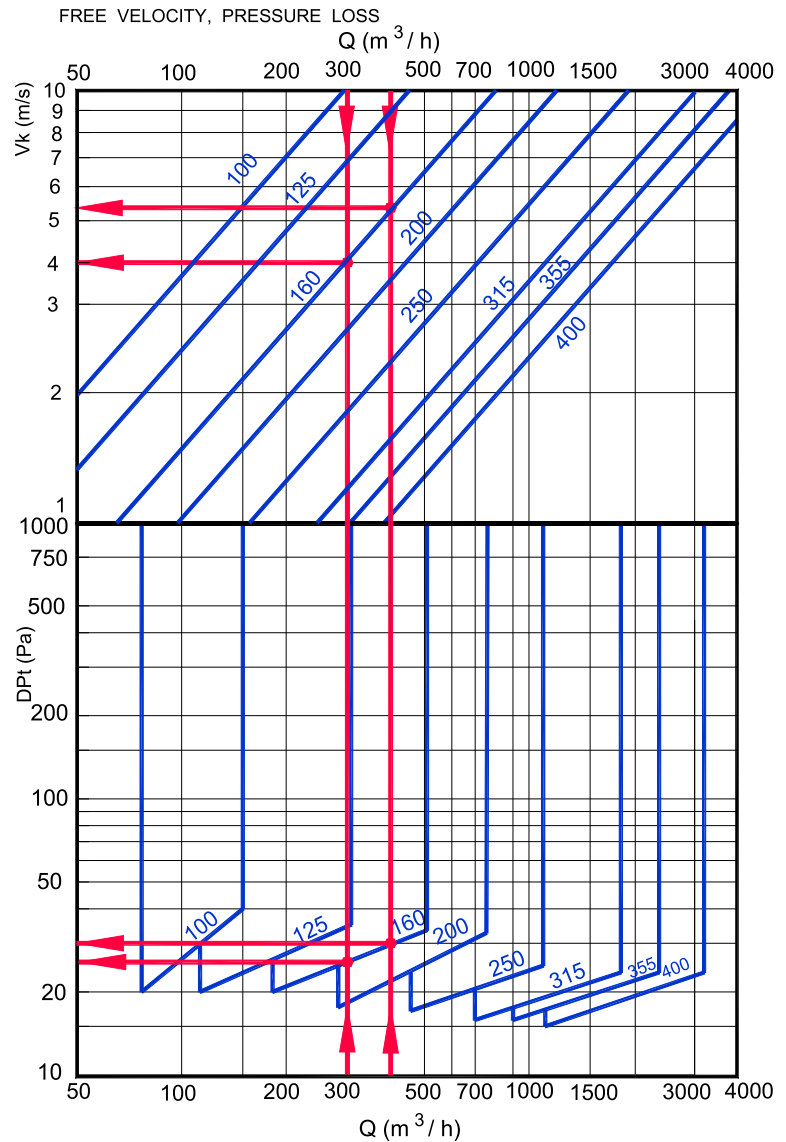

EXAMPLE:

Selection of SVA-C regulator from minimum (V min) and maximum (Vmax) airflow

Minimum Flow. V min (m³/h)

300 m³/h

Minimum Dpt at V min

25 Pa

Velocity in the duct at V min

4 m/s

Maximum flow. V max (m³/h)

453 m³/h

Minimum Dpt at V max

25 Pa

Velocity in the duct at V max

5.2 m/s

Selected dimension

SVA-C 160

CRITERIA TO SET V_{min} and V_{max} .

SVA-C dampers will regulate the airflow, basically to achieve two aims: to maintain setpoint temperature, and to ensure good indoor air quality.

V_{min} the most common criterion to set the minimum flow is the air quality required in the zone to be controlled.

V_{max} the most **common** criterion to set the maximum airflow will be the maximum thermal power to be overcome, which is generally cooling.

DAMPER CONNECTIONS.

There are three basic connection configurations for control. Control in impulsion and return with parallel connection, control in master-slave connection impulsion and return, and control in impulsion only.

Control in impulsion and return allows the same impulsion and return flow or a specific pressure or overpressure in the zone to be maintained.

PARALLEL RETURN IMPULSION CONNECTION.

In parallel control, both the impulsion and the return controller receive the control signal directly from the regulator.

The flows can be set independently between impulsion and return.

This connection system will be used:

- In installations where the impulsion and return dampers have different dimensions or require different minimum and maximum flows between them.
- Systems with several impulsion and return units.
- We recommend installations with parallel connection, since their design, installation and commissioning are more straightforward.

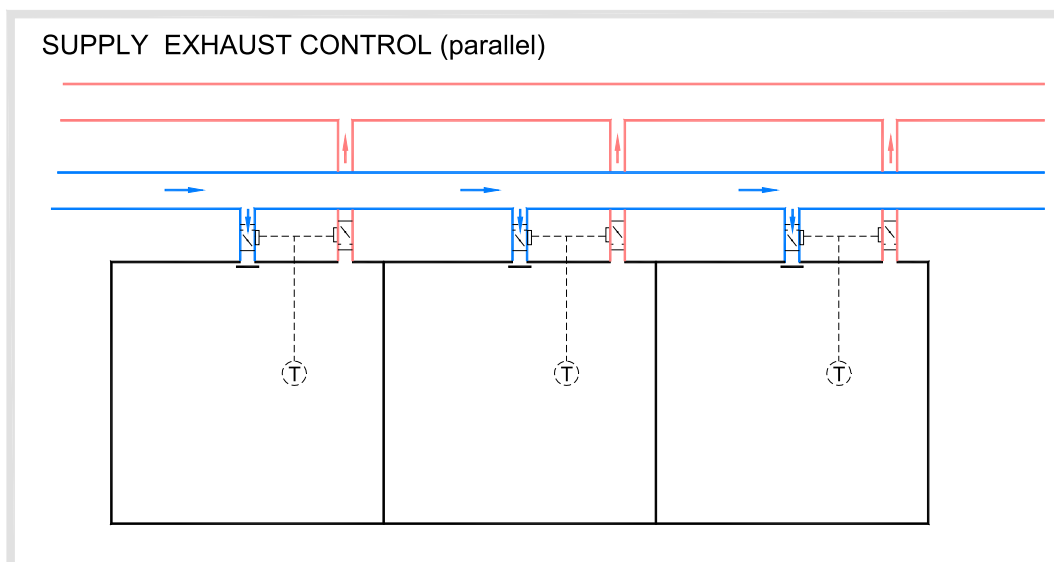
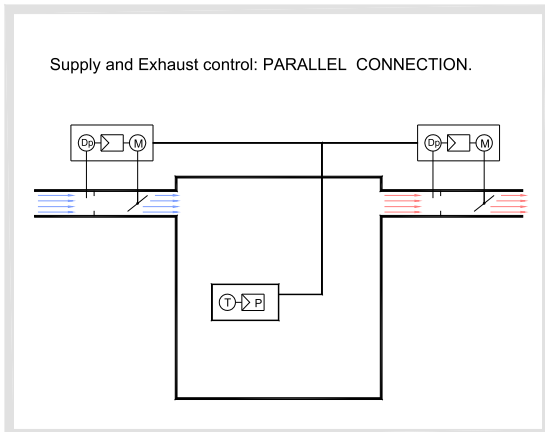

MASTER-SLAVE RETURN IMPULSION CONNECTION.

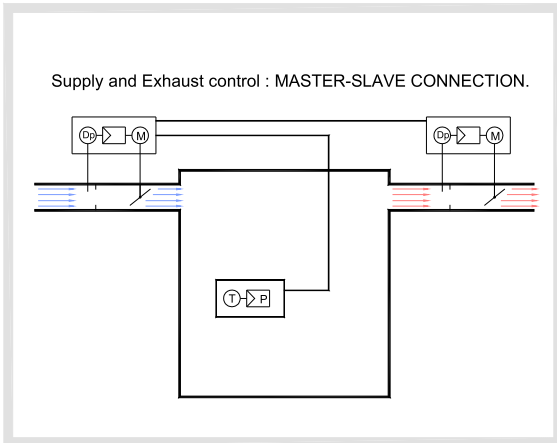

In a Master-Slave control, the regulator sends the setpoint signal to the impulsion damper, and this will send the signal to the return damper which acts as slave to impulsion.

This connection system is used:

- In installations where the return damper works sequentially relative to impulsion.
- In zones where the air impulsion and return dampers have similar dimensions.

Drawbacks

- Each unit must be clearly labelled as a master or a slave, and must be mounted on the correct side (if interchanged, the units must be parametrised again).

The Master-Slave connection requires correct identification throughout the process, from the design, placing of the order, installation and commissioning.

SUPPLY EXHAUST CONTROL (master / slave)

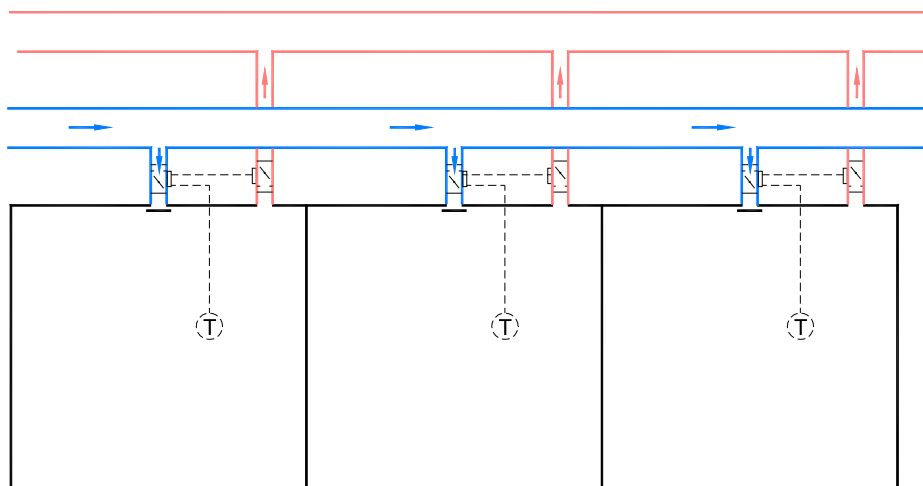

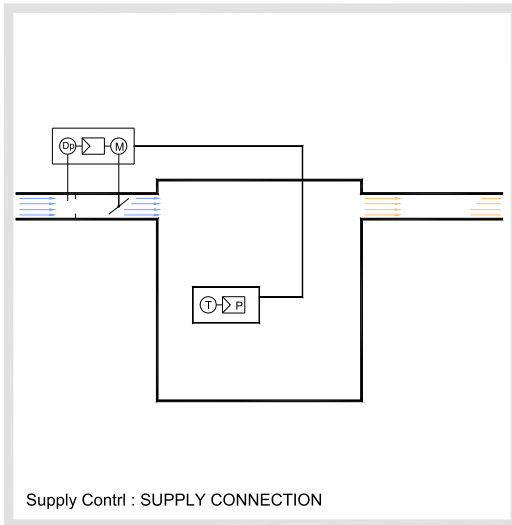

CONTROL IN IMPULSION ONLY

The regulator will only give a signal to the impulsion controller.

Returns are not controlled in this type of installation.

This connection system is used:

It is an economical control since it is not necessary to install the return damper.

This type of installation does not carry out return flow control per zone; this means some zones will be in overpressure and others in underpressure.

SUPPLY CONTROL

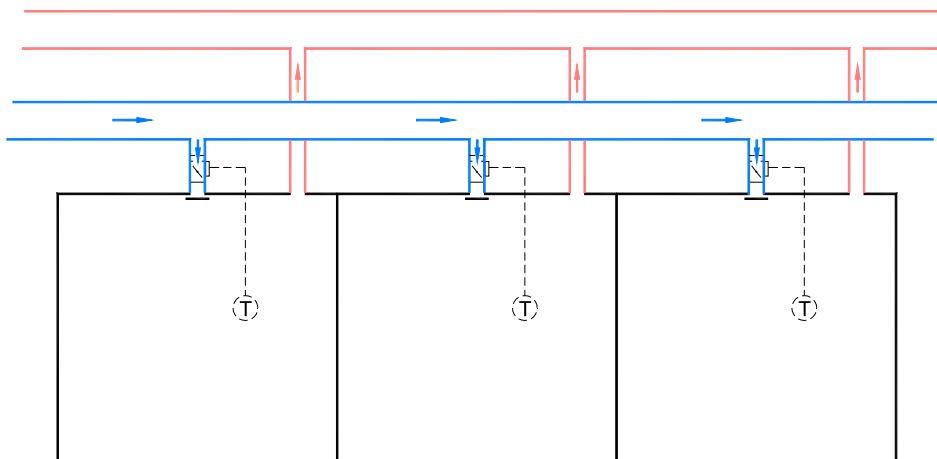

ADJUSTING THE AIRFLOW AND STANDARD CONNECTION.

SVA-C dampers will be supplied with flows **V_{min}** and **V_{max}** preset at factory following the customer's instructions; these flows can be easily modified if necessary with the dampers installed, provided adjustment tools are available.

If the flows to be configured are not indicated in the order, the dampers will be configured with the flows indicated in accordance with the **operation limit**. If only one flow is indicated, this will be considering V_{max} and V_{min} will be the **lower operation limit**.

SVA-C dampers will be configured for parallel connection; configured as Master-Slave upon customer's instructions.

PRECAUTIONS.

The air must be clean in order to avoid contaminating the cross measurement; we recommend filtering in installations whenever the air is dirty (the SVA-C dampers are specially designed for air conditioning facilities).

All obstructions should be prevented between the cross measurement and the servomotor. One of these obstructions may be due to the appearance of condensation inside these sleeves.

When the impulsion air gradient and the air in contact with the sleeve is high, this condensation could damage the servomotor; to avoid this condensation, insulate the sleeves.

ASSEMBLY INSTRUCTIONS.

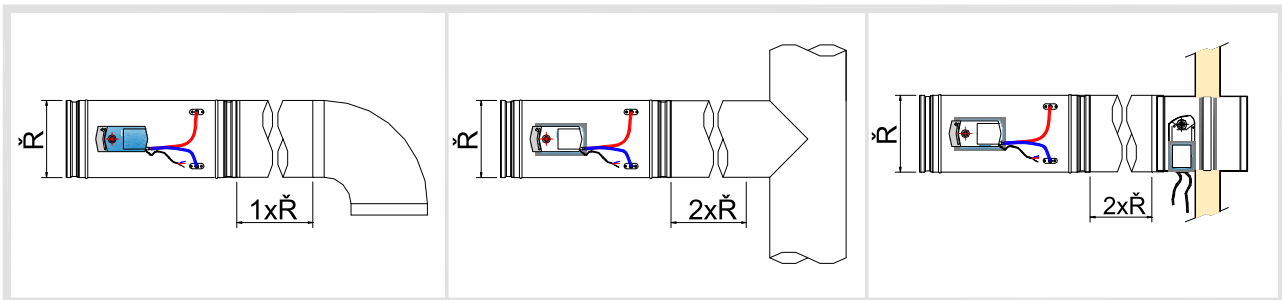

PARTICULARITIES

In VAV installations it is necessary to guarantee the supply of the flows in which they were projected; if the minimum flows are not guaranteed, the dampers never carry out regulation on the flow and will be positioned 100% open.

FORCED OR IMPERATIVE CONTACTS

The servomotors have forced contacts for complete closing or complete opening of the dampers, regardless of the 0-10V signal of the regulator.

These contacts allow the damper to be completely closed if there is nobody present, or completely opened to reach the setpoint more quickly, or force maximum ventilation.

VAV variable airflow - Room Temperature control with Manual changeover. Air supply control.

Wiring diagram **SIEMENS**

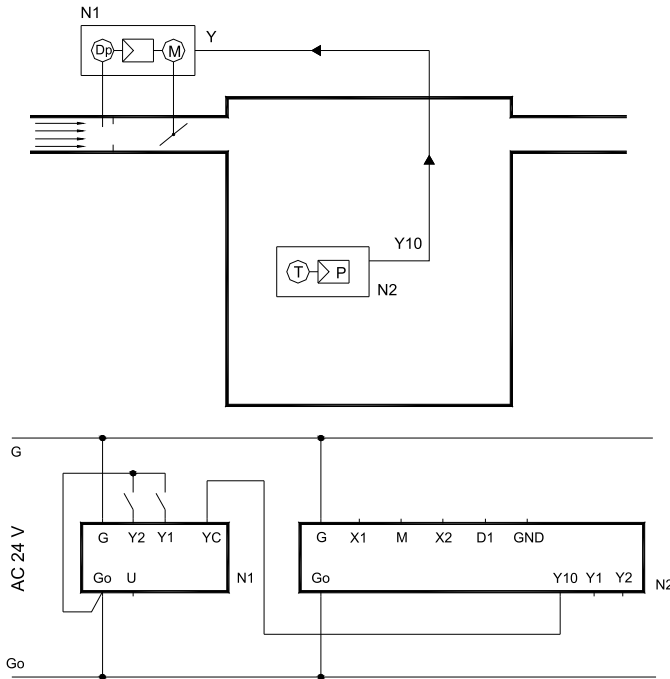

SVA-C / GDB181.1E/3/



RDG 400

N1 SVA-C / GDB181.1E/3

- G Red (RD) Live AC 24 V
- G0 Black (BK) System neutral AC 24 V
- Y1 Violet (VT) Position Signal (factory setting)
- Y2 Orange (OG) Position Signal (factory setting)
- YC Grey (GY) Air volume position signal DC 0...10v
- U Pink (PK) Air volume measuring signal DC 0...10v

N2 RDG 400

- G,G0 Operating voltage AC 24 V
- Y10/G0 Control output for DC 0...0 V actuator
- Y1/G,Y2/G Control output
- X1,X2 Multifunctional input for temperature sensor
 - X1 - external room temperature sensor
 - X2 - switch for automatic heating/cooling changeover
- M Measuring neutral for sensor and switch
- D1,GND Multifunctional input for potential - free switch

GDB181.1E/3 OVERRIDE CONTROL.

Modular control Vmin and Vmax

Fully closed

Fully open

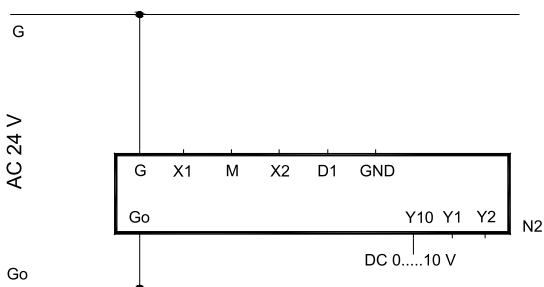
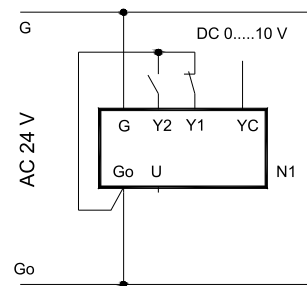
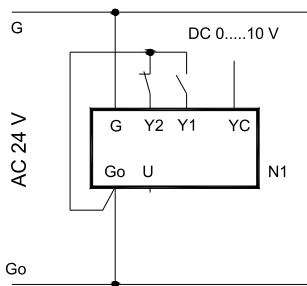
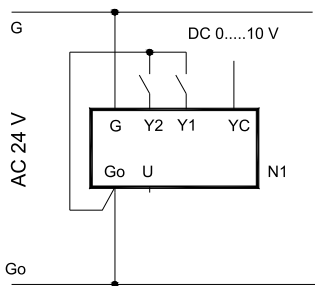

N2 RDG 400 Room temperature controller

Commissioning

DIP Switches



Parameters

- P01.....0 = only heating
- 1 = only cooling (default)
- 2 = manual changeover
- P02-P14.....Default values

VAV variable airflow - Room temperature control with remote changeover. Air supply control.

Wiring diagram **SIEMENS**

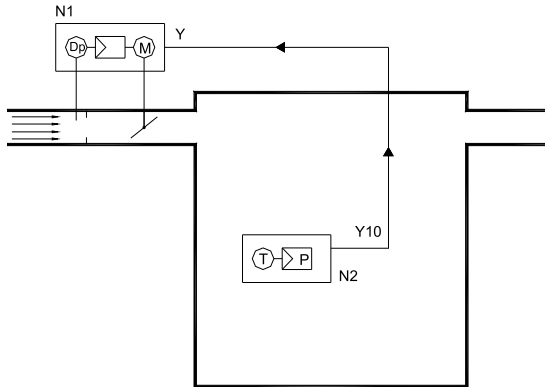

SVA-C /GDB181.1E/3/



RDG 400

N1 SVA-C / GDB181.1E/3

- G Red (RD) Live AC 24 V
- G0 Black (BK) System neutral AC 24 V
- Y1 Violet (VT) Position Signal (factory setting)
- Y2 Orange (OG) Position Signal (factory setting)
- YC Grey (GY) Air volume position signal DC 0...10v
- U Pink (PK) Air volume measuring signal DC 0...10v

N2 RDG 400

- G,G0 Operating voltage AC 24 V
- Y10/G0 Control output for DC 0...0 V actuator
- Y1/G,Y2/G Control output
- X1,X2 Multifunctional input for temperature sensor
 - X1 - external room temperature sensor
 - X2 - switch for automatic heating/cooling changeover
- M Measuring neutral for sensor and switch
- D1,GND Multifunctional input for potential - free switch

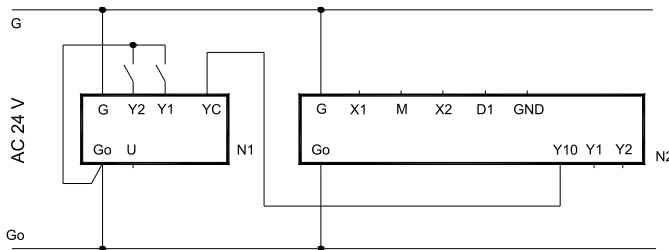

GDB181.1E/3 OVERRIDE CONTROL.

Modular control Vmin and Vmax

Fully closed

Fully open

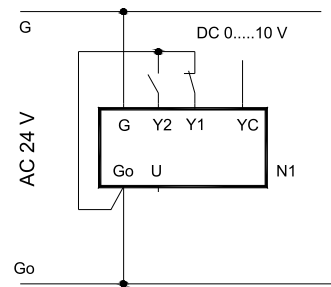
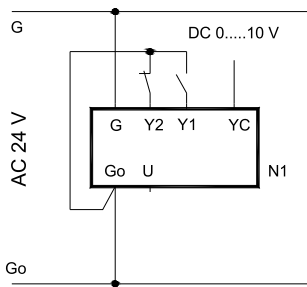
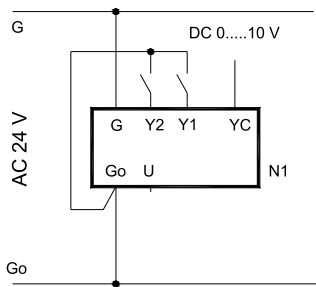

RDG 400

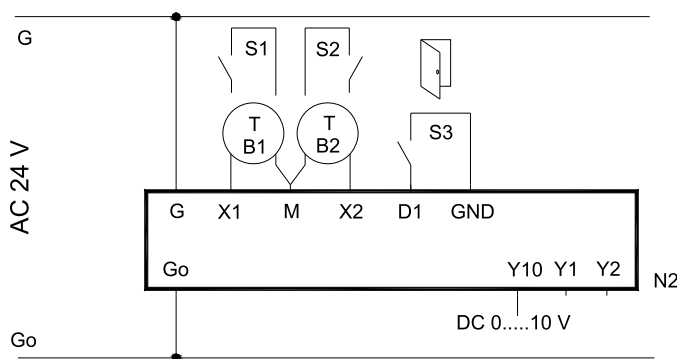

N2 RDG 400 Room temperature controller Commissioning

DIP Switches



Parameters

P01.....3 = Automatic heating/cooling changeover

P02-P14.....Default values

TB2 - Automatic heating/cooling changeover.

Optional - Switch or Sensor QAH11.1
QAH11.1 install in the supply air.

S3 - Optional Switch (keycard, window, contacto, etc)

VAV variable airflow - Room temperature control with remote changeover. Air supply and exhaust control with parallel connection.

Wiring diagram **SIEMENS**



SVA-C / GDB181.1E/3

RDG 400

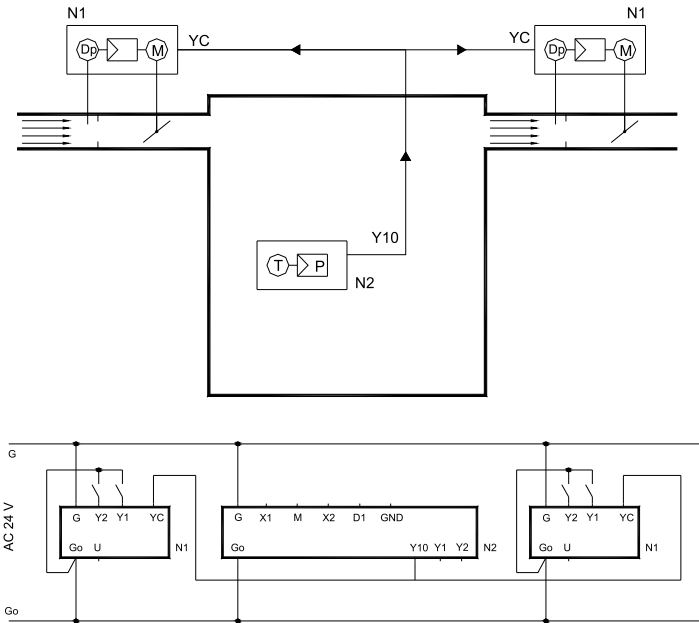

N1 SVA-C / GDB181.1E/3

- G Red (RD) Live AC 24 V
- G0 Black (BK) System neutral AC 24 V
- Y1 Violet (VT) Position Signal (factory setting)
- Y2 Orange (OG) Position Signal (factory setting)
- YC Grey (GY) Air volume position signal DC 0...10v
- U Pink (PK) Air volume measuring signal DC 0...10v

N2 RDG 400

- G, G0 Operating voltage AC 24 V
- Y10/G0 Control output for DC 0...0 V actuator
- Y1/G, Y2/G Control output
- X1, X2 Multifunctional input for temperature sensor
 - X1 - external room temperature sensor
 - X2 - switch for automatic heating/cooling changeover
- M Measuring neutral for sensor and switch
- D1, GND Multifunctional input for potential - free switch

GDB181.1E/3 OVERRIDE CONTROL (must be wired to both actuators).

Modular control Vmin and Vmax

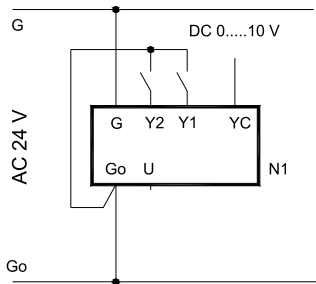

Fully closed

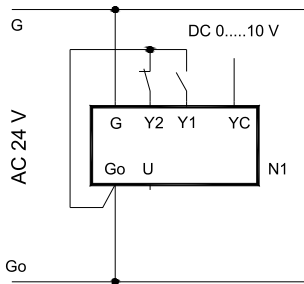

Fully open

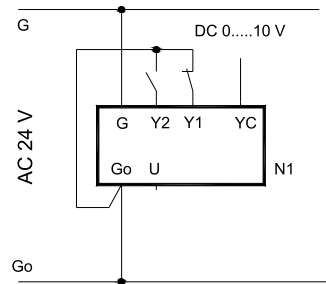

RDG 400

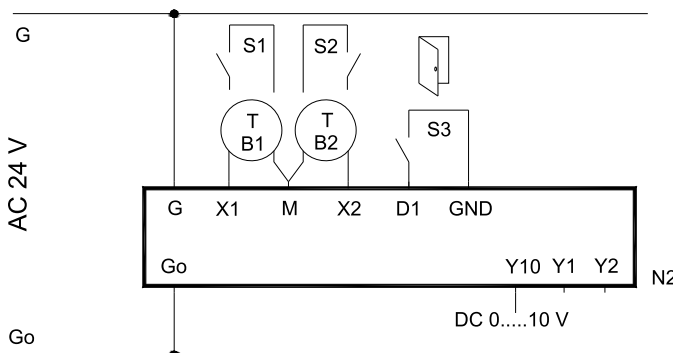

N2 RDG 400 Room temperature controller

Commissioning
DIP Switches



Parameters

P01.....3 = Automatic heating/cooling changeover

P02-P14.....Default values

TB2 - Automatic heating/cooling changeover.

Optional - Switch or Sensor QAH11.1

QAH11.1 install in the supply air.

S3 - Optional Switch (keycard, window, contacto, etc)

VAV variable airflow - RoomTemperature control with remote changeover. Air supply and exhaust control with Master-Slave connection.

Wiring diagram **SIEMENS**

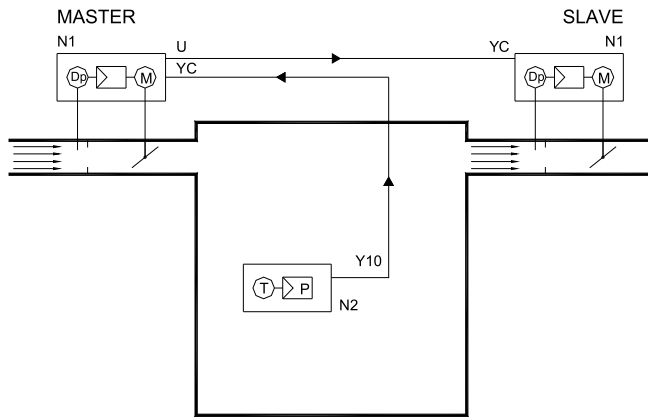

SVA-C / GDB181.1E/3



RDG 400

N1 SVA-C / GDB181.1E/3

- G Red (RD) Live AC 24 V
- G0 Black (BK) System neutral AC 24 V
- Y1 Violet (VT) Position Signal (factory setting)
- Y2 Orange (OG) Position Signal (factory setting)
- YC Grey (GY) Air volume position signal DC 0...10v
- U Pink (PK) Air volume measuring signal DC 0...10v

N2 RDG 400

- G,G0 Operating voltage AC 24 V
- Y10/G0 Control output for DC 0...10 V actuator
- Y1/G,Y2/G Control output
- X1,X2 Multifunctional input for temperature sensor
 - X1 - external room temperature sensor
 - X2 - switch for automatic heating/cooling changeover
- M Measuring neutral for sensor and switch
- D1,GND Multifunctional input for potential - free switch

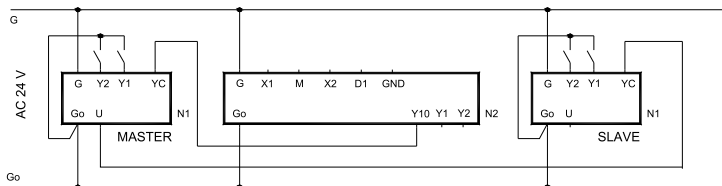

GDB181.1E/3 OVERRIDE CONTROL (must be wired to the MASTER).

Modular control Vmin and Vmax

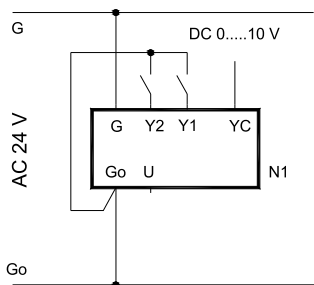

Fully closed

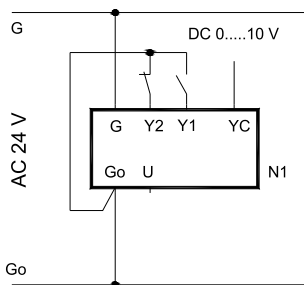

Fully open

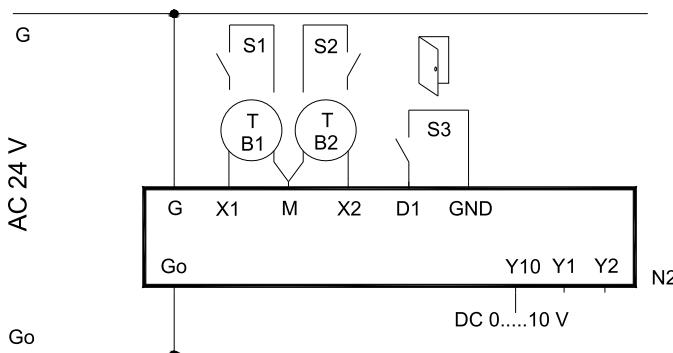
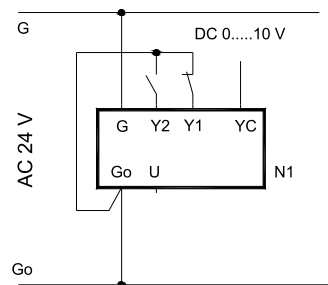

N2 RDG 400 Room temperature controller

Commissioning

DIP Switches

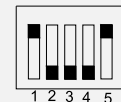

Parameters

P01.....3 = Automatic heating/cooling changeover

P02-P14.....Default values

TB2 - Automatic heating/cooling changeover.

Optional - Switch or Sensor QAH11.1
QAH1.1 install in the supply air.

S3 - Optional Switch (keycard, window, contacto, etc)

VAV variable airflow - Room temperature control centralized , remote changeover.

Air supply control .

Wiring diagram SIEMENS



SVA-C /GDB181.1E/3/



RDG 400



RAK-TR

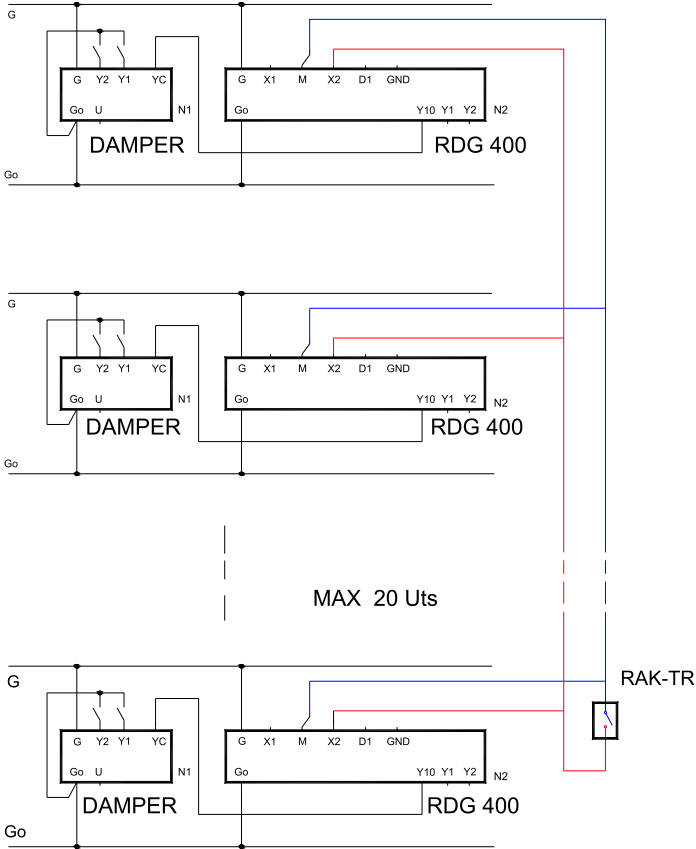
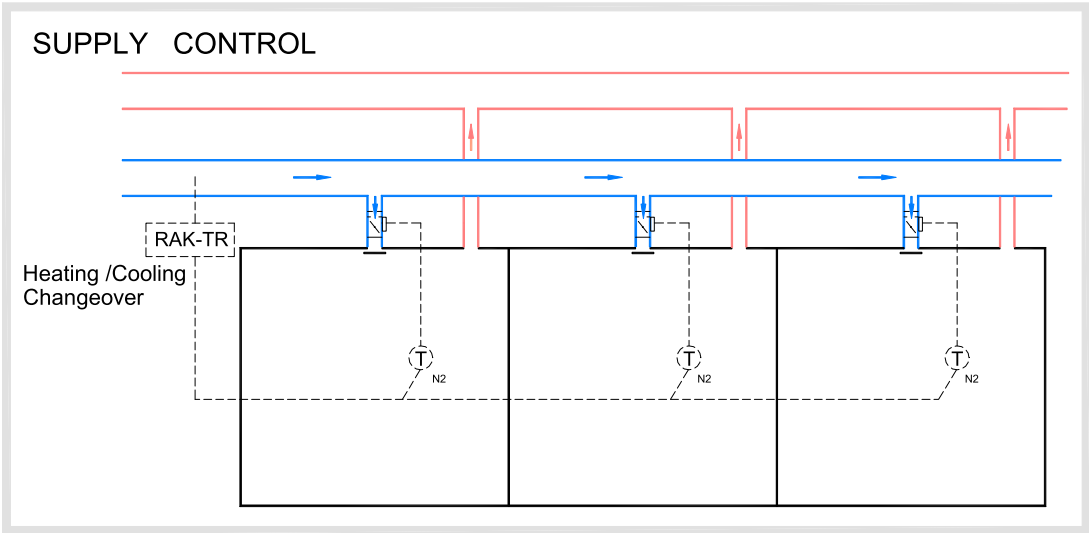

Mechanical Thermostat RAH-TR
 Mechanical immersion thermostat, scale 0° to 40°C,
 differential 2°, heating/cooling,
 Case 200x100 mm, thread 1/2"
 (Select 27°C in the thermostat).

**CAV Constant air flow.
Air supply or exhaust control.**

Wiring diagram **SIEMENS**



SVA-C /GDB181.1E/3/

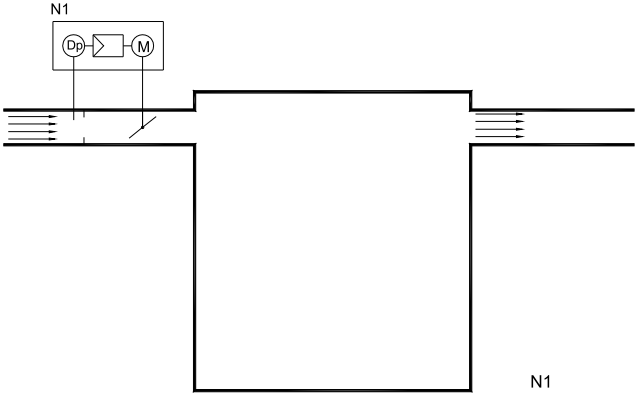

Air supply control.

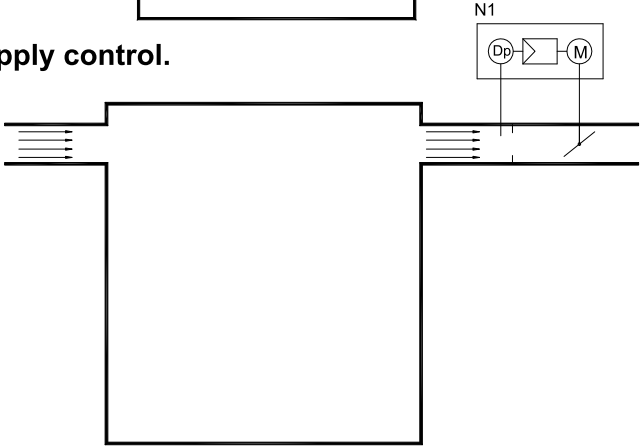

Vmin value

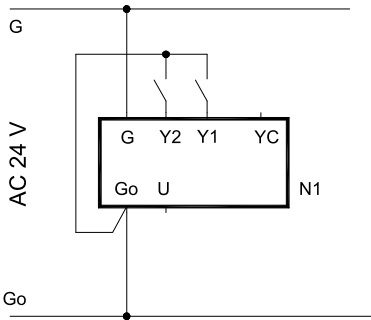

Vmax value

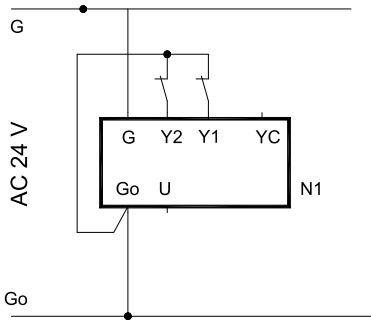

Fully closed

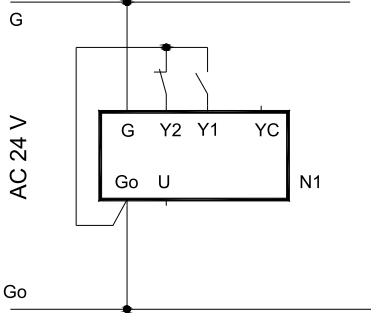

Fully open

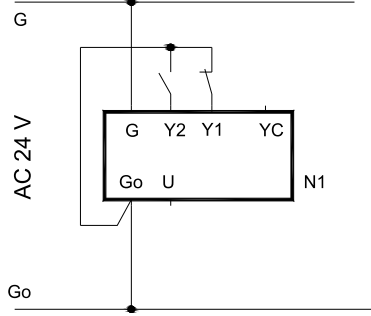

VAV variable airflow - Room CO₂ control. Supply, exhaust, supply and exhaust control.

Wiring diagram SIEMENS

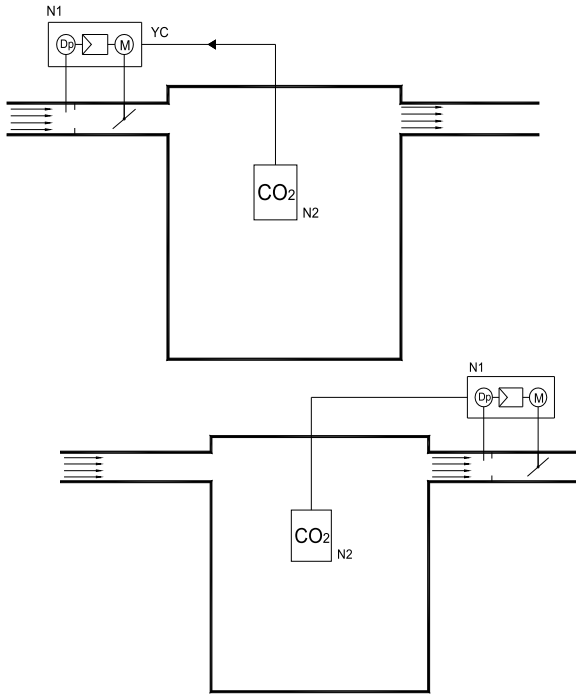

SVA-C /GDB181.1E/3



CO2-WP

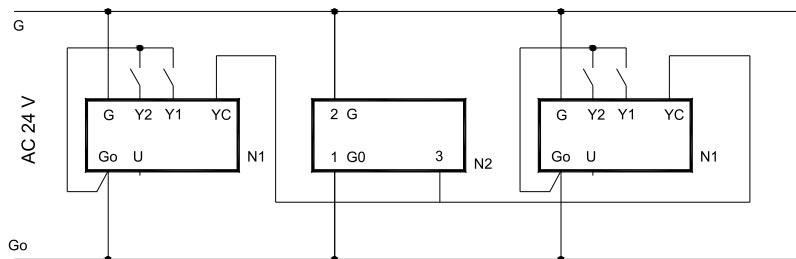
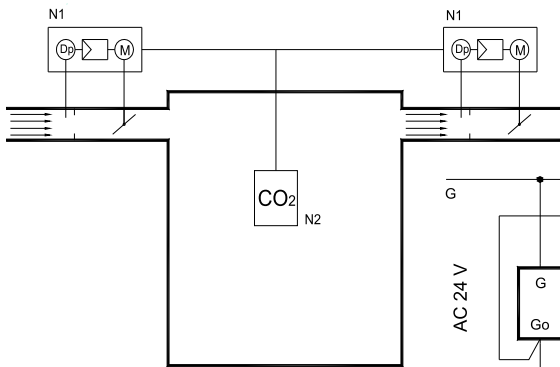
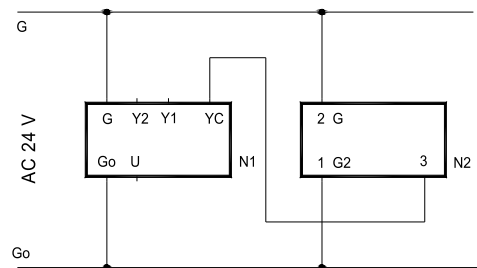

	CO ₂ concentration (ppm)	
	Range	default value
IDA 1 High quality	400	350
IDA 2 Medium quality	400....600	500
IDA 3 Moderate quality	600....1.000	800
IDA 4 Low quality	1.000	1.200

350 ppm: Mean concentration in outside air.

500 to 800 ppm: Comfort conditions in buildings.

1500 ppm: Comfort limit in buildings.

Commissioning. Jumper Position.

	J1	J2
0-10 VDC(default)	disconnected	disconnected
2-10 VDC	connected	disconnected

	J3
PID out put (default)	disconnected
Linear output	connected

	J4	J5
350 ppm	disconnected	disconnected
500 ppm	connected	disconnected
800 ppm (default)	disconnected	connected
1200 ppm	connected	connected

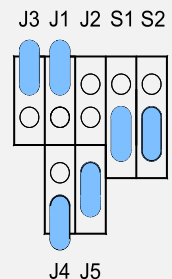

Communicative VAV Air control.

Wiring diagram **SIEMENS**

Air supply control.

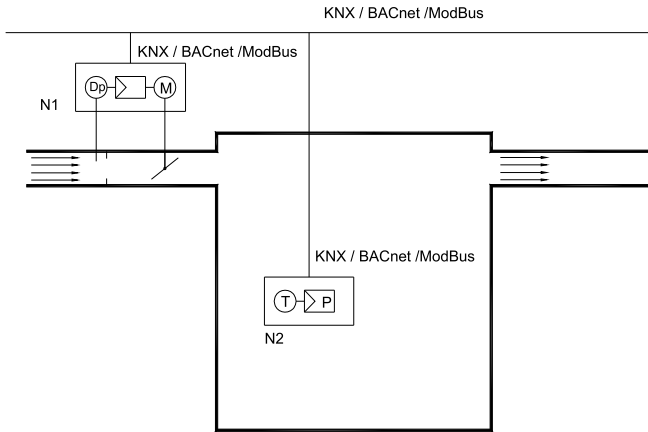

N1 VAV compact air flow controller with Actuator and pressure sensor

N2 Room temperature controller with sensor



N1 SVA-C / GDB181.1E / KN /

- 1 Red (RD) System voltage AC 24 V
- 2 Black (BK) System neutral AC 24 V
- 6 Violet (VT) Reference
- 8 Grey (GY) Bus (KNX RTU)
- 9 Pink (PK) Bus (KNX RTU)

Air supply and exhaust control.

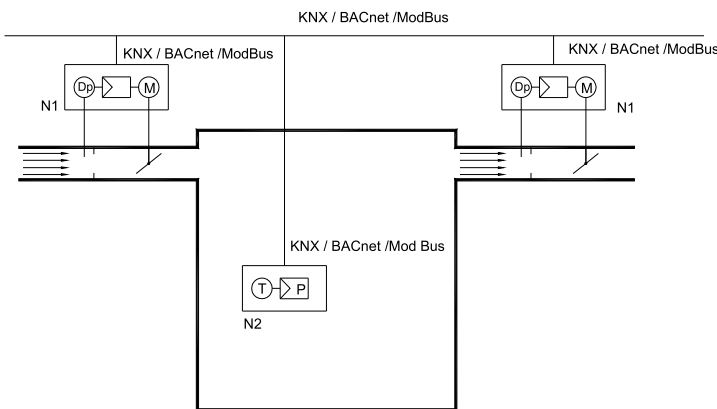

N1 SVA-C / GDB181.1E / BA /

- 1 Red (RD) System voltage AC 24 V
- 2 Black (BK) System neutral AC 24 V
- 6 Violet (VT) Reference
- 8 Grey (GY) Bus (BACnet RTU)
- 9 Pink (PK) Bus (BACnet RTU)



N1 SVA-C / GDB181.1E / MO /

- 1 Red (RD) System voltage AC 24 V
- 2 Black (BK) System neutral AC 24 V
- 6 Violet (VT) Reference
- 8 Grey (GY) Bus (Modbus RTU)
- 9 Pink (PK) Bus (Modbus RTU)

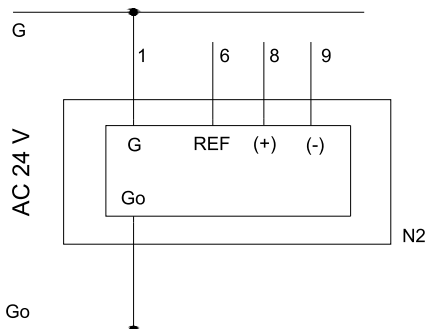

VAV variable airflow - Room Temperature control with remote changeover. Air supply Control.

Wiring diagram **BELIMO**

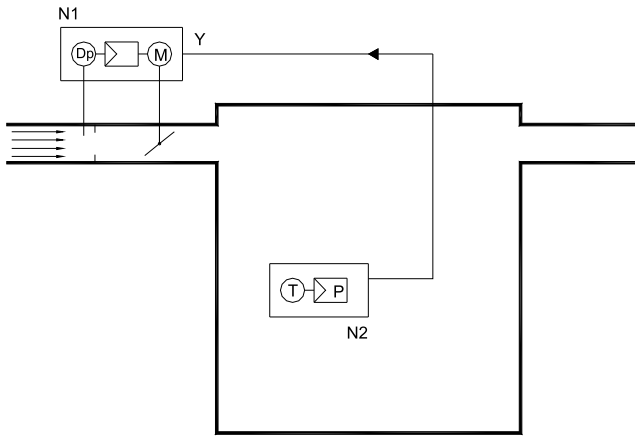

SVA-C / LMV-D3-MP/



CR24-B1

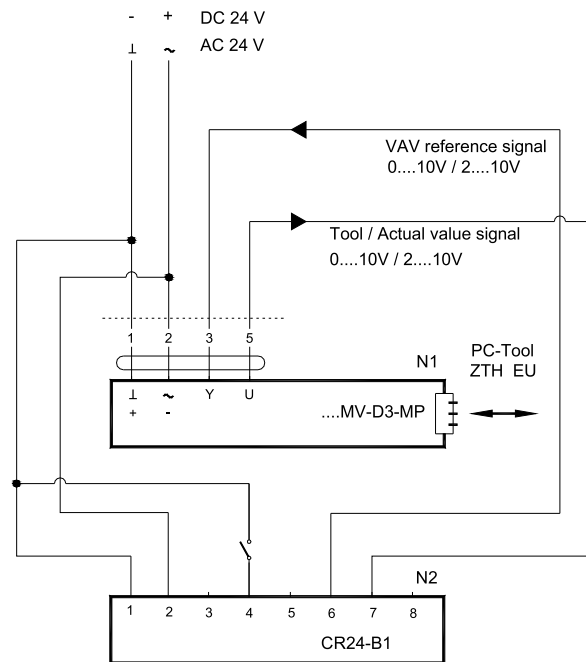
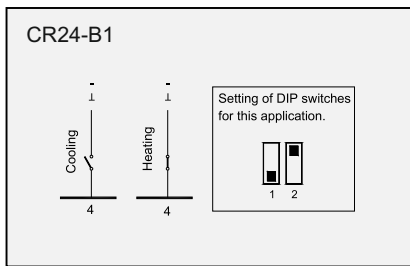

OVERRIDE CONTROL

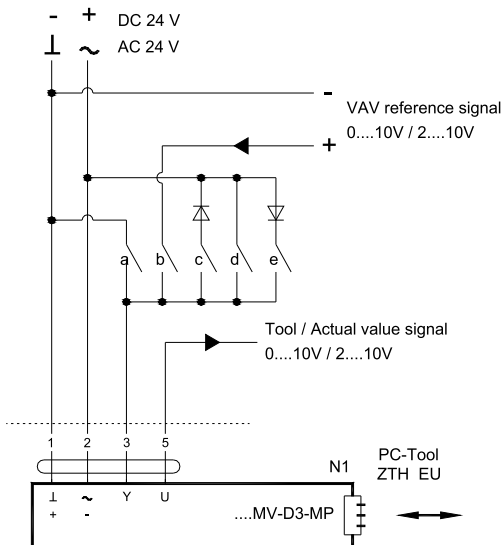

	a	b	c	d	e
Mode setting	- 2...10 V	0...10 V 2...10 V	0...10 V 2...10 V	0...10 V 2...10 V	0...10 V 2...10 V
Signal	⊥	0...10 V 2...10 V	~	~ +	~
Function	3	3	3	3	3
Damper CLOSED	CLOSED		CLOSED		
\checkmark min... \checkmark max		VAV			
CAV... \checkmark min	ALL open - \checkmark min active				
Damper OPEN					OPEN
CAV... \checkmark max				\checkmark max	

Note. Only one contact closed at same time.

Signals 'c' and 'e' only available with AC 24 V supply.

VAV variable airflow - Room Temperature control. Air supply air.

Wiring diagram **BELIMO**



SVA-C / LMV-D3-MP/

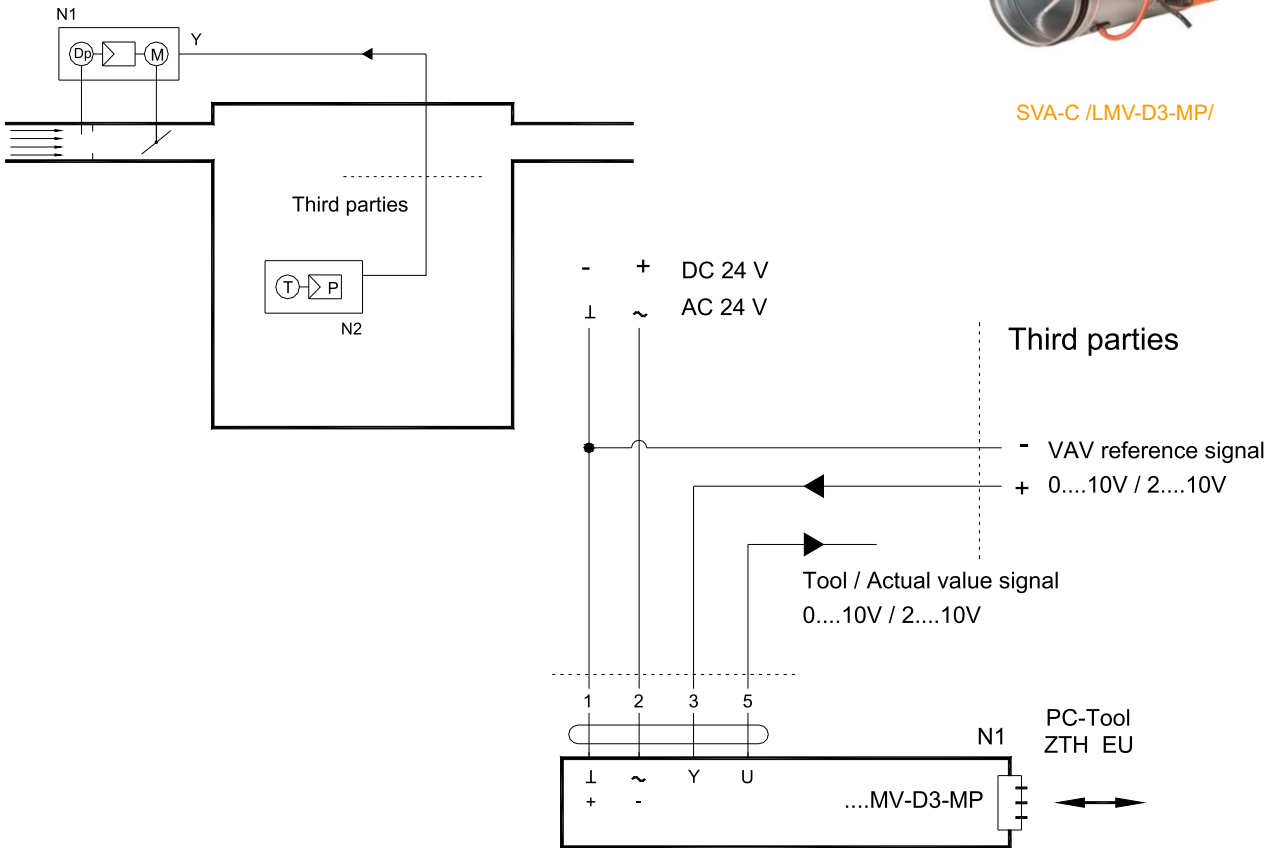

OVERRIDE CONTROL

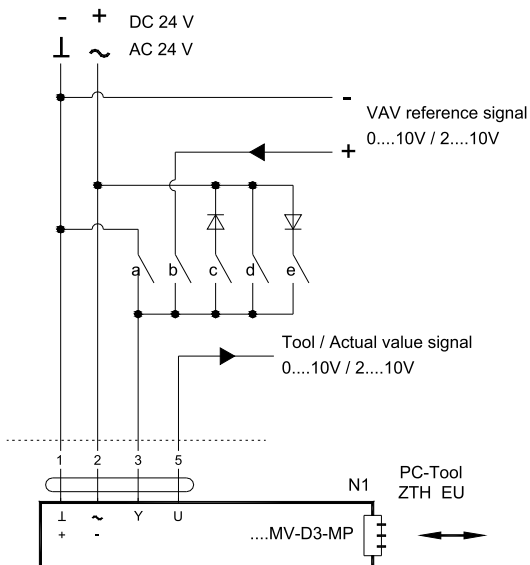

	a	b	c	d	e
Mode setting	-	0...10 V	0...10 V	0...10 V	0...10 V
	2...10 V	2...10 V	2...10 V	2...10 V	2...10 V
Signal	⊥	0...10 V 2...10 V	~	~+	~
Function	⊕ 3	⊕ 3	⊕ 3	⊕ 3	⊕ 3
Damper CLOSED	CLOSED		CLOSED		
\checkmark min... \checkmark max		VAV			
CAV... \checkmark min	ALL open - \checkmark min active				
Damper OPEN					OPEN
CAV... \checkmark max				\checkmark max	

Note. Only one contact closed at same time.

Signals 'c' and 'e' only available with AC 24 V supply.

VAV variable airflow - Room temperature control. Air supply and exhaust control with Parallel connection.

Wiring diagram **BELIMO**



SVA-C /LMV-D3-MP/

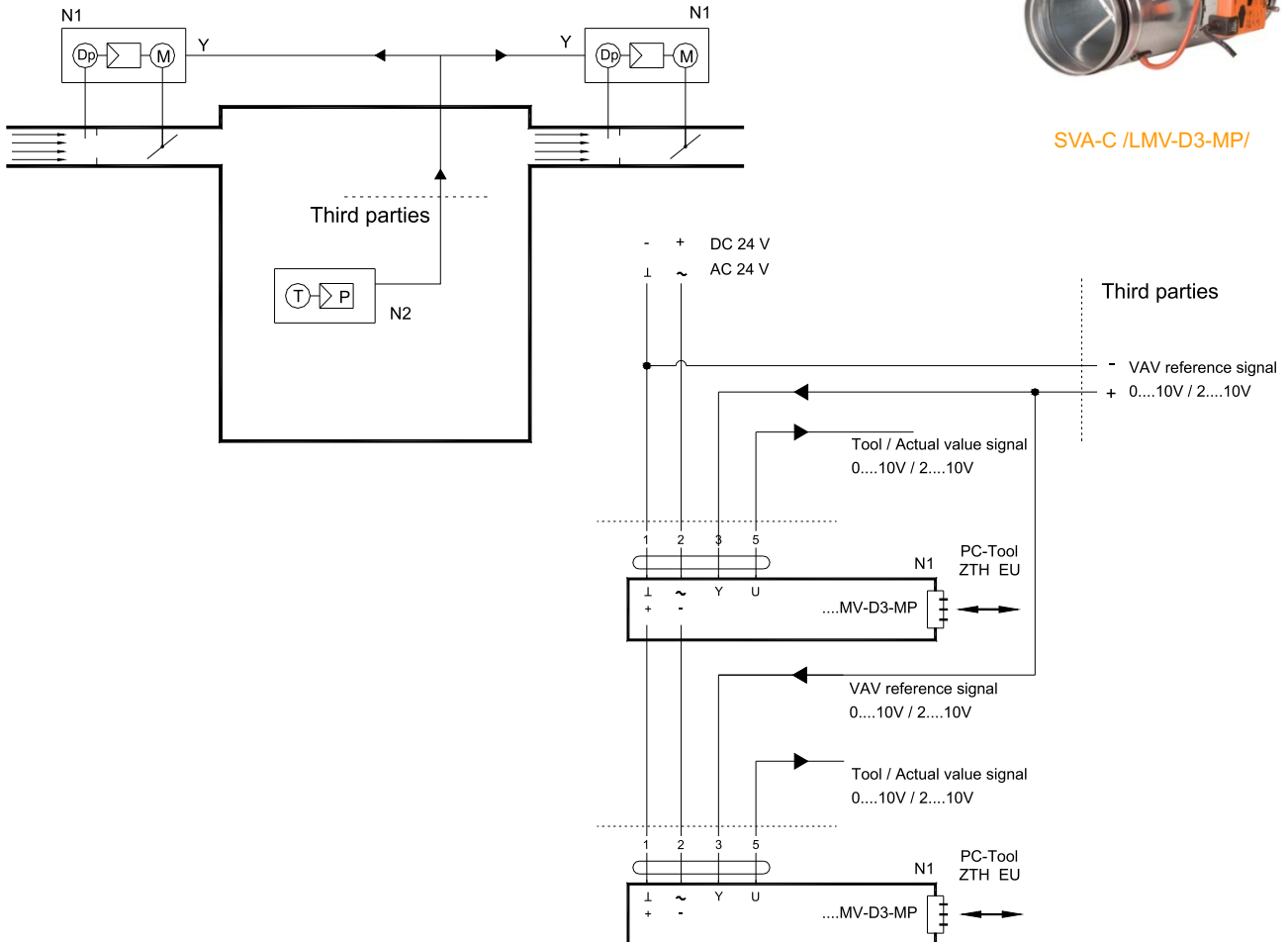

VERRIDE CONTROL (must be wired to both actuators)

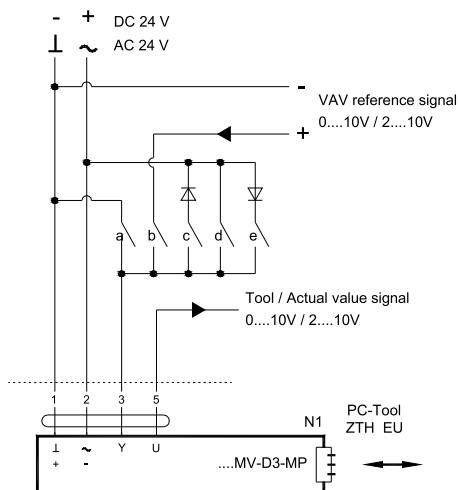

	a	b	c	d	e
Mode setting	-	0...10 V	0...10 V	0...10 V	0...10 V
Mode setting	2...10 V	2...10 V	2...10 V	2...10 V	2...10 V
Signal	$\frac{1}{-}$	$\frac{0...10 V}{2...10 V}$	\sim	\sim	\sim
Function					
Damper CLOSED	CLOSED		CLOSED		
\checkmark min... \checkmark max		VAV			
CAV... \checkmark min	ALL open - \checkmark min active				
Damper OPEN					OPEN
CAV... \checkmark max				\checkmark max	

Note. Only one contact closed at same time.

Signals 'c' and 'e' only available with AC 24 V supply.

VAV variable airflow – Room temperature control. Air supply and exhaust control with Master-Slave connection.

Wiring diagram **BELIMO**



SVA-C / LMV-D3-MP/

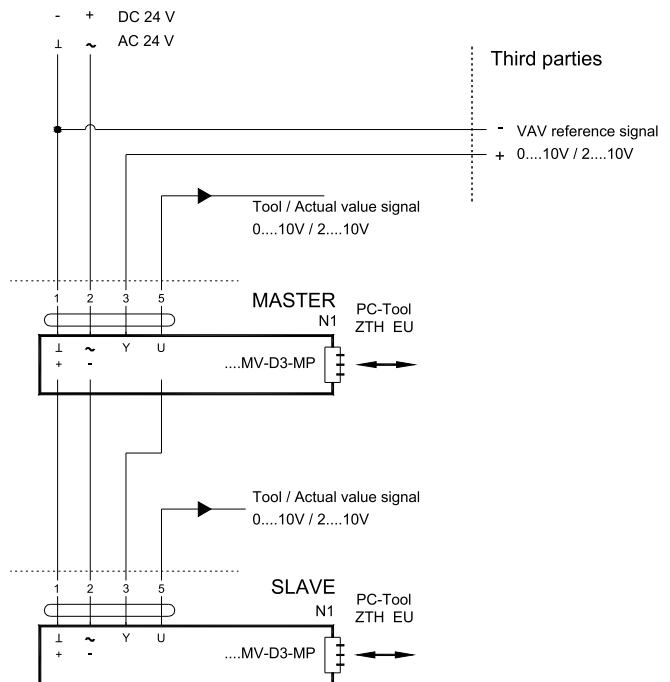
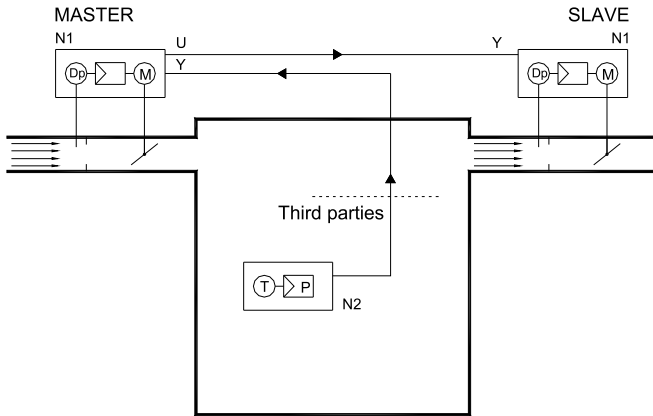

VERRIDE CONTROL (must be only wired to the MASTER)

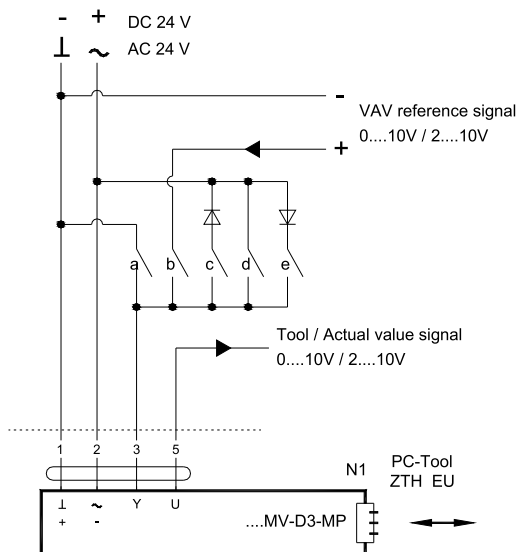

	a	b	c	d	e
Mode setting	-	0...10 V	0...10 V	0...10 V	0...10 V
	2...10 V	2...10 V	2...10 V	2...10 V	2...10 V
Signal	\perp	0...10 V 2...10 V	\sim	\sim +	\sim
Function	\odot 3	\odot 3	\triangle 3	\odot 3	∇ 3
Damper CLOSED	CLOSED		CLOSED		
\dot{V} min... \dot{V} max		VAV			
CAV... \dot{V} min	ALL open - \dot{V} min active				
Damper OPEN					OPEN
CAV... \dot{V} max				\dot{V} max	

Note. Only one contact closed at same time.

Signals 'c' and 'e' only available with AC 24 V supply.

VAV variable airflow - Room temperature control with centralized, remote changeover Air supply control.



SVA-C / LMV-D3-MP/



CR24-B1



RAK-TR

- + DC 24 V
I ~ AC 24 V

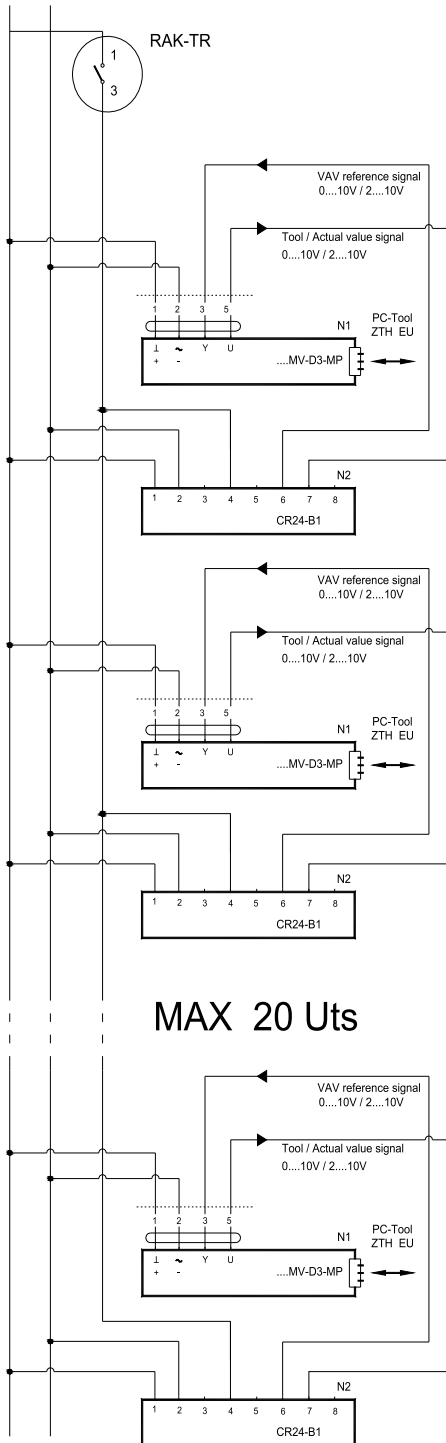

MAX 20 Uts

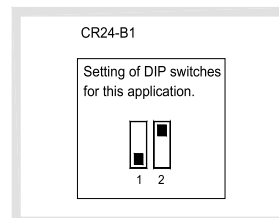
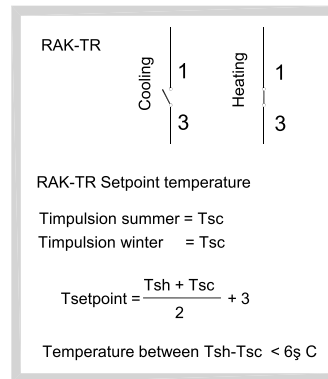
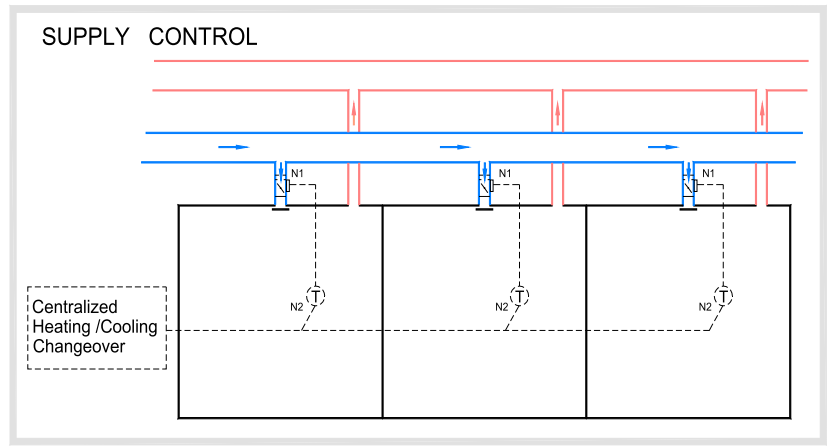

CAV Constant air flow.
Air supply or exhaust Control.

Wiring diagram BELIMO



SVA-C / LMV-D3-MP/

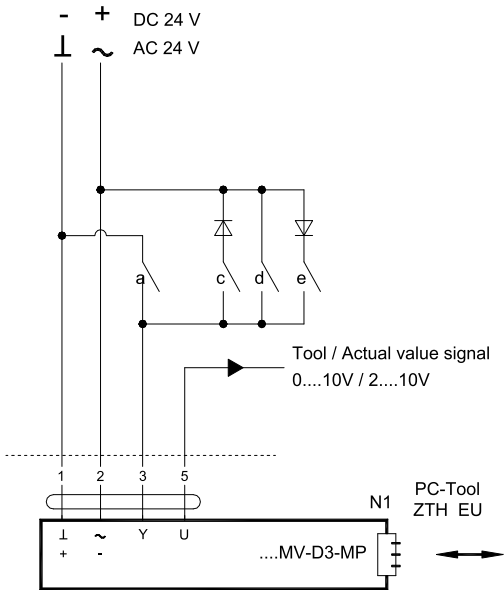
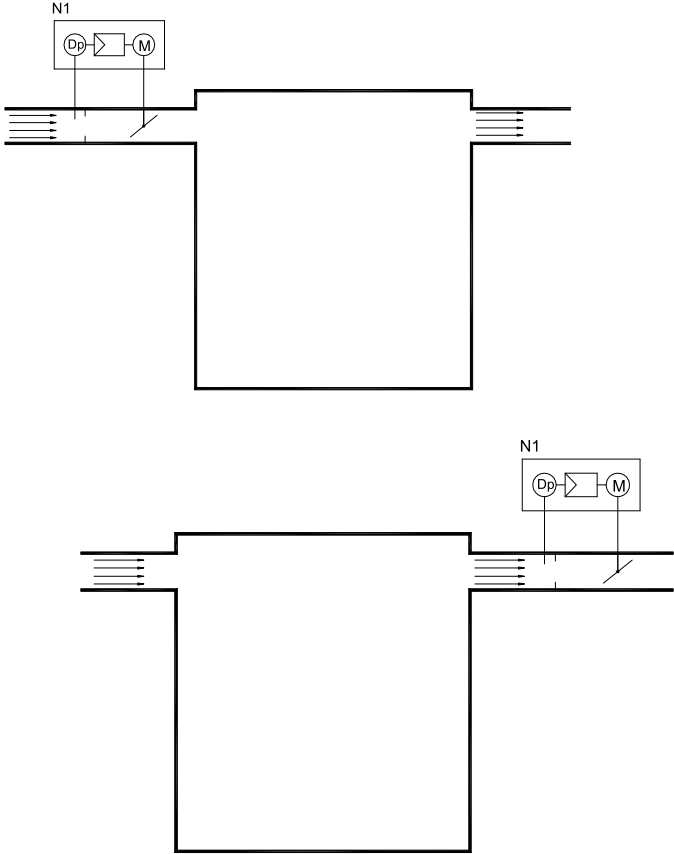

	a	c	d	e
Mode setting	-	0.....10 V	0.....10 V	0.....10 V
	2.....10 V	2.....10 V	2.....10 V	2.....10 V
Signal				
Function				
Damper CLOSED	CLOSED	CLOSED		
Damper OPEN				OPEN
CAV... \dot{V} max			\dot{V} max	

Note. Only one contact closed at same time.
 Signals 'c' and 'e' only available with AC 24 V supply.

VAV variable airflow - Room CO₂ control. Supply, exhaust, supply and exhaust control.

Wiring diagram BELIMO

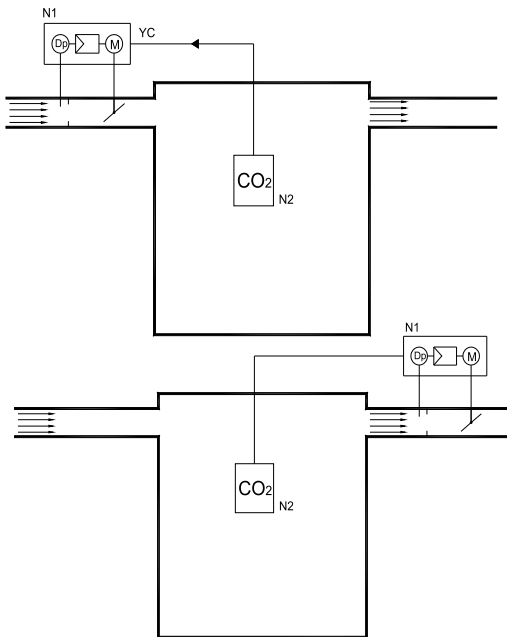

SVA-C / LMV-D3-MP/

CO₂-WP

- + DC 24 V
1 ~ AC 24 V

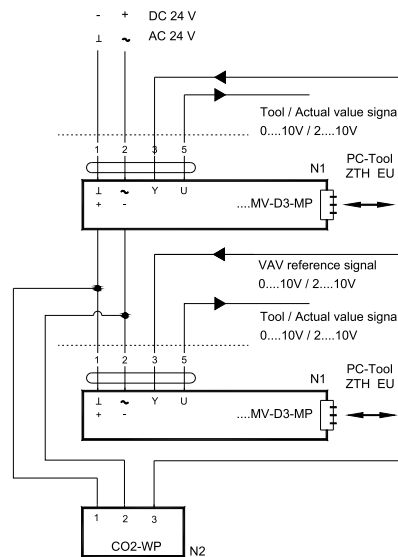
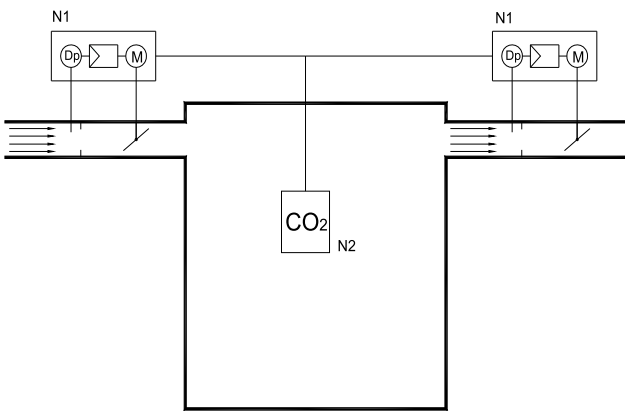
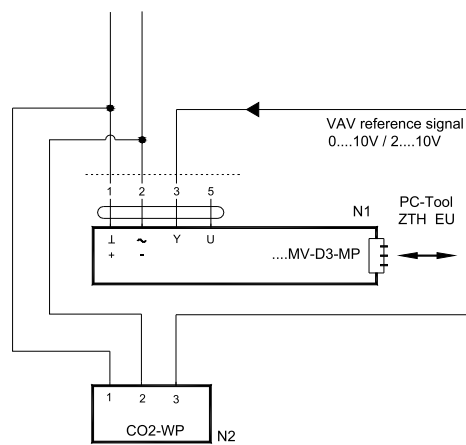

	CO ₂ concentration (ppm)	
	Range	default value
IDA 1 High quality	400	350
IDA 2 Medium quality	400...600	500
IDA 3 Moderate quality	600...1.000	800
IDA 4 Low quality	1.000	1.200

350 ppm: Mean concentration in outside air.

500 to 800 ppm: Comfort conditions in buildings.

1500 ppm: Comfort limit in buildings.

Commissioning. Jumper Position.

	J1	J2
0-10 VDC (default)	disconnected	disconnected
2-10 VDC	connected	disconnected

	J3
PID out put (default)	disconnected
Linear output	connected

	J4	J5
350 ppm	disconnected	disconnected
500 ppm	connected	disconnected
800 ppm (default)	disconnected	connected
1200 ppm	connected	connected

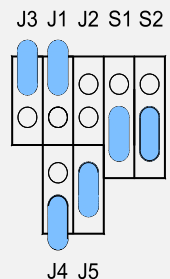

Communicative VAV Air control.

Wiring diagram **BELIMO**

Air supply control.

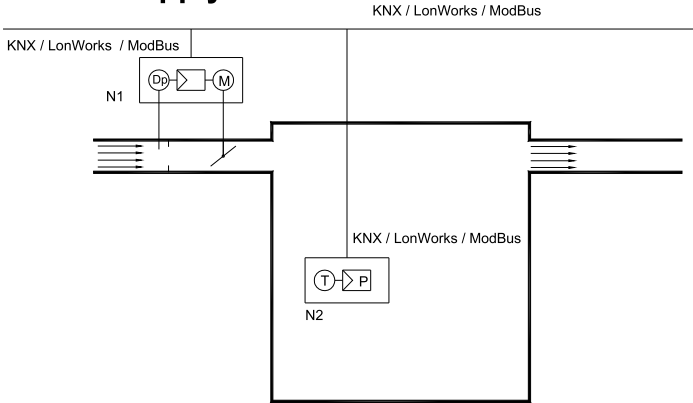

N1 -VAV compact air flow controller with actuator and pressure sensor

N2 Room temperature controller with sensor



N2.....SVA-C / LMV-D3-MOD /

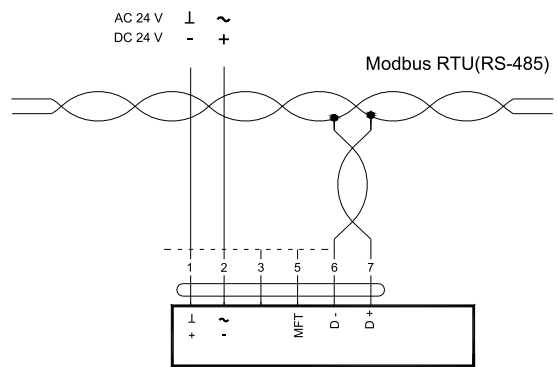

Air supply and exhaust control.

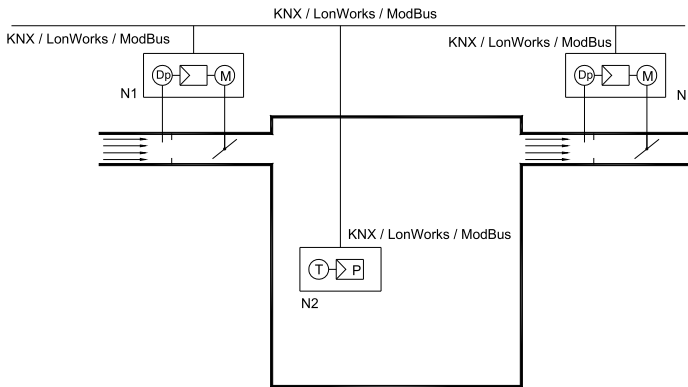

N2.....SVA-C / LMV-D3-LON /

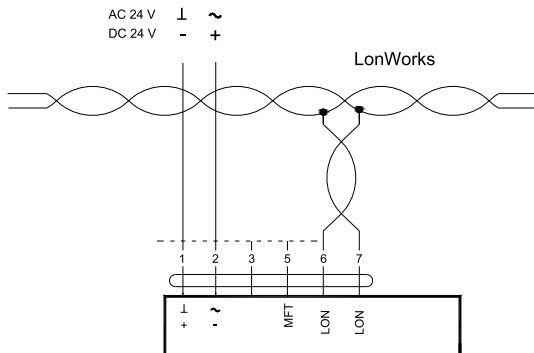

N2.....SVA-C / LMV-D3-KNX /

